

## SPECIFICATIONS

	THB-6048	THB-6048HD	THB-6048XHD
Charge Chamber Opening Size	60" x 48"	60" x 48"	60" x 48"
Bale Size	60" x 48" x 30"	60" x 48" x 30"	60" x 48" x 30"
Bale Weight	1200 to 1300 lbs	1300 to 1400 lbs	1400 to 1500 lbs
Ram Penetration	45"	45"	45"
Baling Force Normal	76,930 lbs	113,000 lbs	156,860 lbs
Baling Force Maximum	92,316 lbs	135,600 lbs	184,632 lbs
Cycle Time	55 sec. (no load)	65 sec. (no load)	65 sec. (no load)
System Pressure Normal	2,000 psi	2,000 psi	2,000 psi
System Pressure Maximum	2,400 psi	2,400 psi <td 2,400 psi	
Pump Capacity	38 gpm (Hi-Lo)	48 gpm (Hi-Lo)	58 gpm (Hi-Lo)
Motor Size	20 hp	30 hp	40 hp
Cylinder Type	1 x 7"	2 x 6"	2 x 7"
Ram Face Pressure Normal	42.7 psi	62.8 psi	85.5 psi
Ram Face Pressure Maximum	51.3 psi	75.4 psi	102.6 psi
Oil Tank Capacity	125 gal	175 gal	225 gal
Shipping Weight	14,500 lbs	15,500 lbs	18,500 lbs

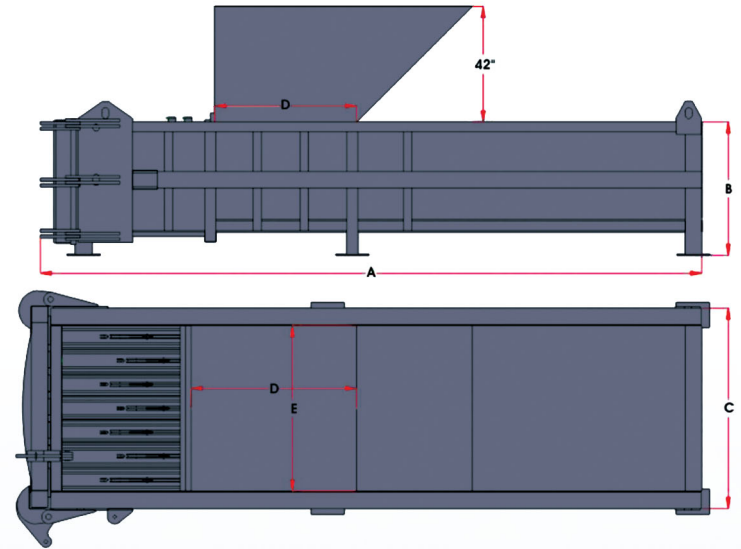

## ELECTRICAL

Control System	110 Volt 60 Cycle powered by step-down transformer
Control Panel	Fully wired, keyed start button, emergency stop, full light, reset button, plc, current sensor
Power	208/230/575 Volt, 3 Phase 60 cycle

## DIMENSIONS

	A	B	C	D	E
THB-6048	218"	48"	72"	48"	60"
THB-6048HD	218"	48"	72"	48"	60"
THB-6048XHD	218"	48"	72"	48"	60"

### STANDARD ELECTRICAL FEATURES

- ▶ UL/CSA Approved Design
- ▶ Meets/exceeds OSHA regulations
- ▶ PLC "flex-design" based control systems
- ▶ NEMA 4 rated enclosure
- ▶ Internal timers prevent system run-on
- ▶ 24-volt controls
- ▶ Adjustable multi-cycle timer
- ▶ 75% and 100% full light
- ▶ Heavy duty oil-tight pushbutton controls
- ▶ Key lockable start pushbutton

### HYDRAULIC SYSTEM UPGRADES

- ▶ Single phase and three phase power units
- ▶ Hi-lo hydraulic pumps
- ▶ Regen circuit
- ▶ Oil cooler
- ▶ Bio-degradable oil
- ▶ In tank oil heater
- ▶ Low temperature oil (as low as -60 Celsius available)

### ELECTRICAL SYSTEM UPGRADES

- ▶ System monitor
- ▶ Remote start/stop station
- ▶ Auto-start system (photo-eye or sonic sensor)
- ▶ Wireless remote control
- ▶ Biometric interface
- ▶ HMI based operator interface

### COMPACTOR UPGRADES

- ▶ Custom chute systems
- ▶ Custom weather enclosures
- ▶ Drive-on deck systems (certified up to 20,000 lbs.)
- ▶ Tongue and grooved floor designs
- ▶ AR plate floors and sides
- ▶ Custom hydraulic cart tipping systems
- ▶ Custom steel safety barriers
- ▶ Custom hydraulic lift systems

This Equipment is UL/CSA Approved and Conforms to all Current ANSI Z245.2 Safety Standards

In order to provide the most currently engineered and designed equipment, we reserve the right to change specifications without notice. This brochure is intended to provide information only, and should not be used in an arbitrary manner to judge equipment for any particular purpose.

