

# TRI-PAK TB4222 SERIES BALERS

## MECHANICAL

	4222
BALE SIZE	42" x 22" x 24"
BALE WEIGHT	75 to 110 lbs
CYLINDER SIZE	1 x 4" Ø
FULL PENETRATION CYL.	n / a
BALING FORCE NORMAL	25,120 lbs
BALING FORCE MAXIMUM	27,632 lbs
SYSTEM PRESSURE NORMAL	2,000 psi
SYSTEM PRESSURE MAXIMUM	2,200 psi
CYCLE TIME	42 seconds
PUMP CAPACITY	Hi / Lo
MOTOR SIZE	1 & 3 hp
PLATEN PRESSURE NORMAL	27.2 psi
PLATEN PRESSURE MAXIMUM	29.9 psi
OIL TANK CAPACITY	1 & 5 gal
BALE EJECTION	chain free
SHIPPING WEIGHT	1,250 lbs

## ELECTRICAL

CONTROL SYSTEM	110 VOLT 60 CYCLE POWERED BY STEP-DOWN TRANSFORMER
CONTROL PANEL	FULLY WIRED. KEYED START BUTTON, EMERGENCY STOP, FULL LIGHTS, RESET BUTTON
POWER	115 / 230V, 1ph & 208/460/575V, 3ph

## DIMENSIONS

	A	B	C	D	E	F
4222	92"	62"	51"	29"	29"	21"

## STANDARD FEATURES

- ▶ UL/CSA Approved Design
- ▶ Heavy Duty Oil Tight Pushbutton Controls
- ▶ Chain Free Bale Ejection System
- ▶ Automatic Single Cycle Operation
- ▶ PLC Based Controls
- ▶ Full Bale Light

## OPTIONAL EQUIPMENT

- ▶ Deep Chamber (36")
- ▶ Full Bale Light
- ▶ Hydraulic Bale Dump
- ▶ R.H. Hinged Bale Door
- ▶ Pull Down Feed Gate
- ▶ Rear Wire Guides

This Equipment is UL/CSA Approved and  
Conforms to all Current ANSI Z245.2  
Safety Standards.

In order to provide the most currently engineered and designed  
equipment, We reserve the right to change specifications without notice.  
This brochure is intended to provide information only, and should not  
be used in an arbitrary manner to judge equipment for any particular purpose.

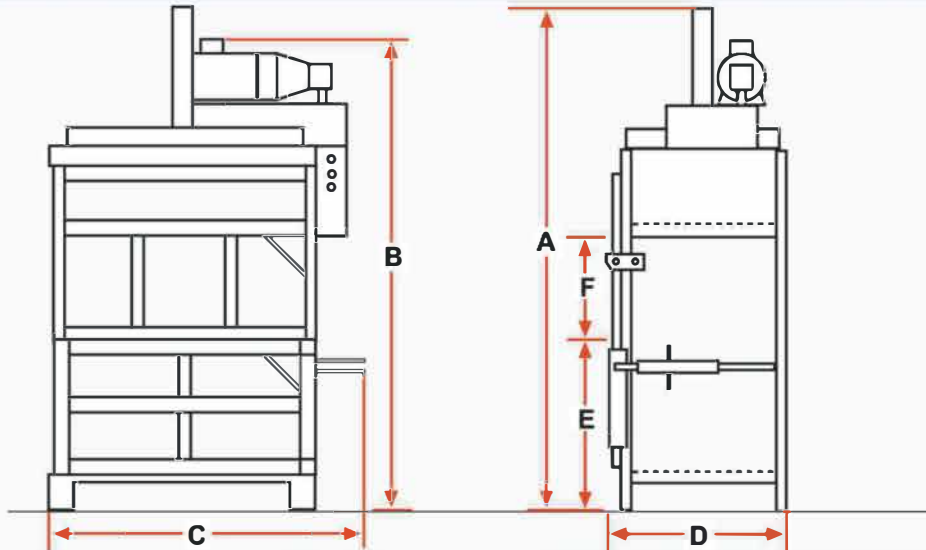

DISTRIBUTED BY:



**REACTION**  
DISTRIBUTING INC.  
**THE TREND SETTERS**  
19 Brock Street, Ajax, Ontario L1S 1S9

Tel: 905-426-6442 Fax: 905-426-5925 www.balers.ca