

SPECIFICATIONS

	T-20X
Charge Chamber Volume	0.25
Charge Chamber Opening Size	27" x 25"
Ram Face Size	27" x 15"
Ram Penetration	5"
Compaction Force Normal	19,625 lbs
Compaction Force Maximum	23,550 lbs
Cycle Time	25 seconds
System Pressure Normal	2,000 psi
System Pressure Maximum	2,200 psi
Pump Capacity	2 gpm
Motor Size	1 hp
Cylinder Size	2 x 2.5"
Cylinder Type	Double Acting
Ram Face Pressure Normal	48.5 psi
Ram Face Pressure Maximum	58.1 psi
Oil Tank Capacity	5 gal
Shipping Weight	950 lbs

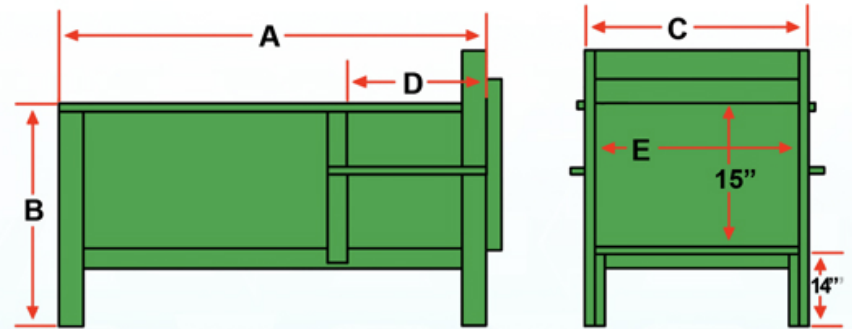
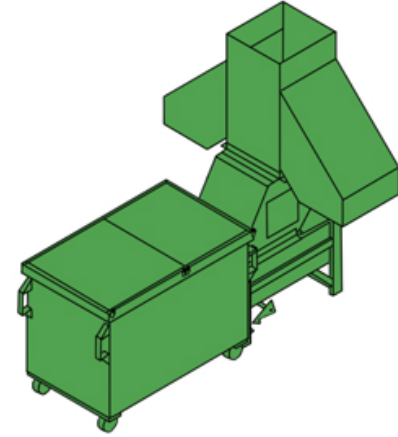

ELECTRICAL

Control System	110 Volt 60Hz
Control Panel	keyed power on, power on light, emergency stop, bin full light, system reset
Power	208 / 230 / 575V, 3ph, 60Hz & 110V, 1ph, 60Hz

DIMENSIONS

	A	B	C	D	E
T-20X	52"	34"	31"	25"	27"

STANDARD FEATURES

- ▶ CSA Approved Design
- ▶ Heavy Duty Oil - tight Pushbutton Controls
- ▶ Key Lockable Start Pushbutton
- ▶ Automatic Single - cycle Operation
- ▶ PLC Controlled System
- ▶ Full - Container Light

OPTIONAL EQUIPMENT

- ▶ Advance - warning light
- ▶ Fluid - filled Pressure Gauge
- ▶ Oil Heater
- ▶ Odor Control System
- ▶ Open Hopper (for top or dock loading)
- ▶ Fully Enclosed Hopper with Door
- ▶ Through the Wall Installation Kits
- ▶ Walk-on or Drive-on Decks
- ▶ Safety Gate
- ▶ Hydraulic Cart-Dump Systems

This Equipment is CSA Approved and Conforms to all Current ANSI Z245.2 Safety Standards

In order to provide the most currently engineered and designed equipment, we reserve the right to change specifications without notice. This brochure is intended to provide information only, and should be used in an arbitrary manner to judge equipment for any particular purpose.

